

CINETIK™ Linear Electro-Dewatering Solutions

A breakthrough technology available today

Eimco Water Technologies' Linear Electro-Dewatering solutions revolutionize the way water is extracted from industrial and municipal sludge. Our Cinetik™ Line of Products extract water more efficiently and at a much lower cost than currently available processes because, unlike heat based dryers and incinerators, the Cinetik technology does not evaporate the water; it relies on the combined action of a controlled mechanical pressure and electro-osmosis, where an electrical field generated inside the sludge liberates and carries away the water bonded to hydrophilic particles. When removed of their excess water and pathogens, sludge is turned into a valuable resource and can be reused as a fertilizer or as a renewable fuel source.

Cinetik A-Series Line of Products

EWT's Cinetik Line of Products incorporates the electro-dewatering process in a metallic structure (2) housing a linear filter belt (4) arrangement which moves the sludge cake along multiple serviceable power blocks (3) that apply pressure and DC current via modular rectifiers (1) to the sludge, hence dewatering it. When applied to a sludge of about 10–15% dryness, the Cinetik process can yield dryness levels of 30 to 50% or greater.

Cinetik Equipment Features

- Low footprint
- Robustness
- Simple, fingertip operation
- Adjustments for varying sludge characteristics and desired parameters (energy consumption, final dryness level, etc.)

- Seamless integration with your existing process and equipment
- A sustainable solution which curtails costs and facilitates disposal or recycling of biosolids

Whether your capacity requirements are in the hundreds of kilograms per hour or several hundred tons per day, EWT's Cinetik linear electro-dewatering systems are the solution to control your sludge management costs.

Contact an Eimco Water Technologies representative in order to evaluate your potential savings, organize a demo or visit one of our commissioned installations.

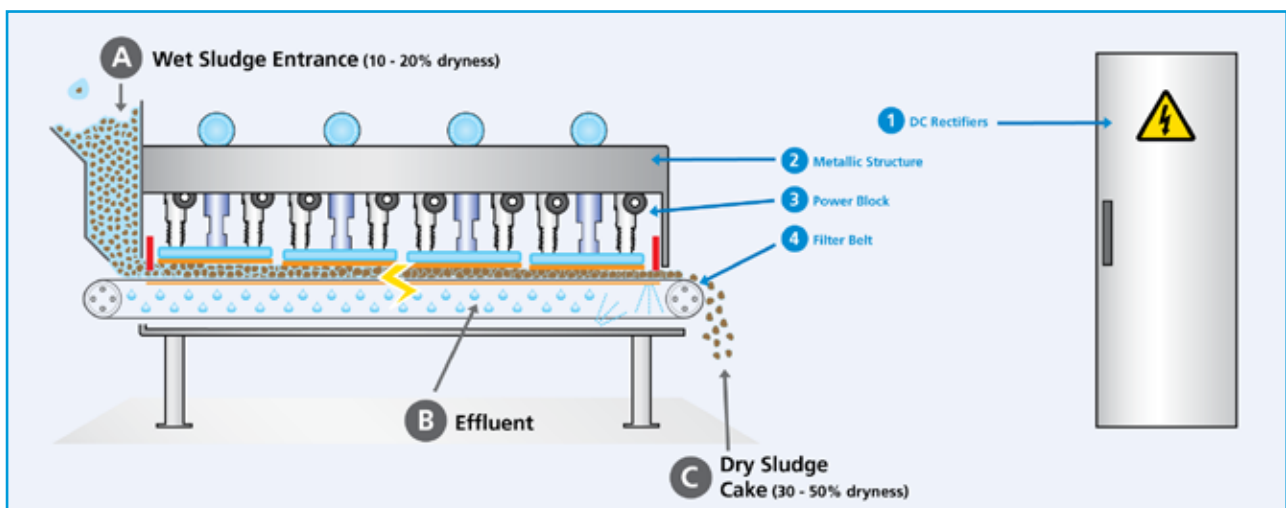

CINETIK™ Linear Electro-Dewatering Solutions

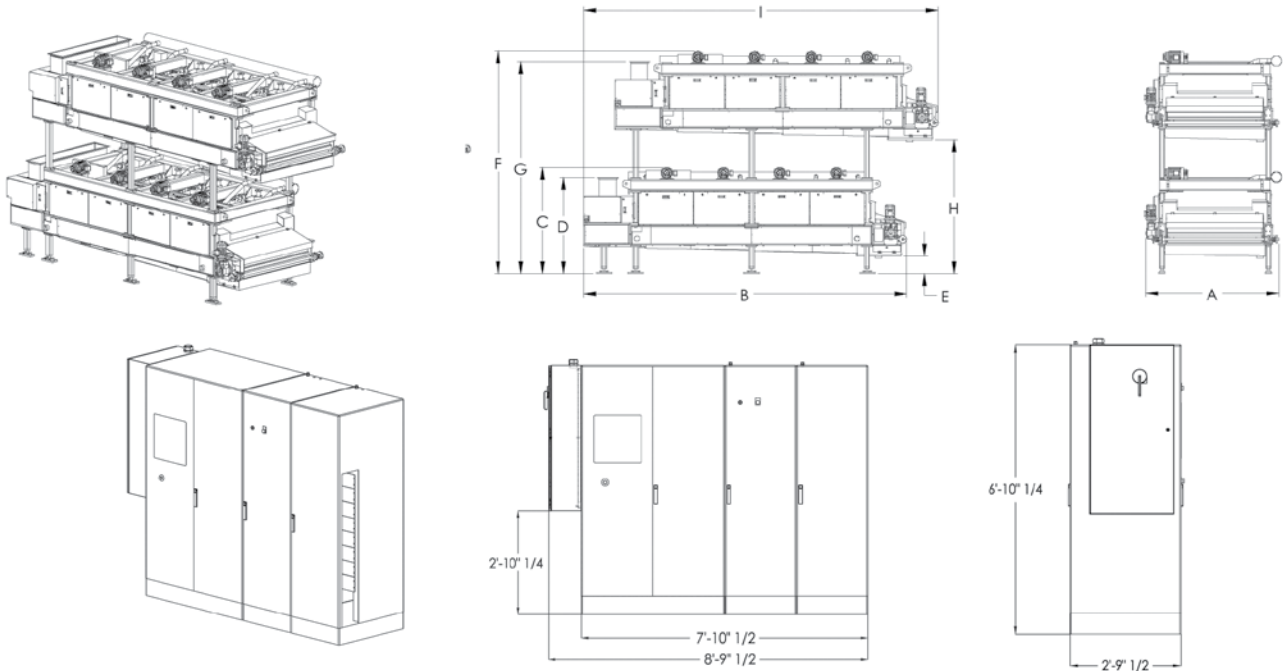

Dimensions of available models

	Cinetik™ 800	Cinetik™ 1600-2
A	8'-6" (2.60m)	8'-6" (2.60m)
B	20'-8" (6.30m)	20'-8" (6.30m)
C	6'-11 1/2" (2.07m)	6'-11 1/2" (2.07m)
D	6'-1 3/4" (1.87m)	6'-1 3/4" (1.87m)
E	1'-1 1/2" (0.34m) Typ	1'-1 1/2" (0.34m) Typ
F	N/A	13'-6 1/2" (4.13m)
G	N/A	12'-10 3/4" (3.93m)
H	N/A	7'-10 1/2" (2.40m)
I	N/A	22'-7 3/4" (6.90m)

Specifications

Rated capacity* (wet sludge) ¹ (t/h)*	0.8–1.2 (0.7–1.1)	1.5–2.4 (1.4–2.2)
Weight of unit (t)*	15 (13.6)	30 (27.2)
Weight of panel (t)*	1.5 (1.4)	1.5 (1.4) x 2 units
Installed power (kW) ²	216	432
Usable power, typ. (kW) ²	180	360
Voltage ³ (V) 60Hz, 3 phase	360–460	360–460
Minimal fed sludge dryness	-10% TS	-10% TS

*(in metric)

¹ Values shown are for illustrative purposes only. Actual values depend on wet sludge dryness, final dryness required, type and source of sludge to be treated.

² Rectifier power only (standard configuration). Additional rectifiers can be installed with an option fee.

³ Other electrical specification (frequency, voltage) available upon request.